

oerlikon
barmag

Rectangular melt spinning pumps

For manmade fibers



Rectangular gear spinning pumps

Oerlikon Barmag has been manufacturing precision gear pumps for the manmade fiber industry since 1922. From pump generation to pump generation, trendsetting innovations have constantly set new standards.

Many years of experience, innovative ideas, and modern manufacturing methods, coupled with a steadfast quality philosophy, continue to ensure that Oerlikon Barmag maintains a leading position among pump manufacturers.

Whenever precise metering of polymer melts or additives is required, Oerlikon Barmag gear pumps are the right choice.

The necessary pump size can be calculated with the following formula:

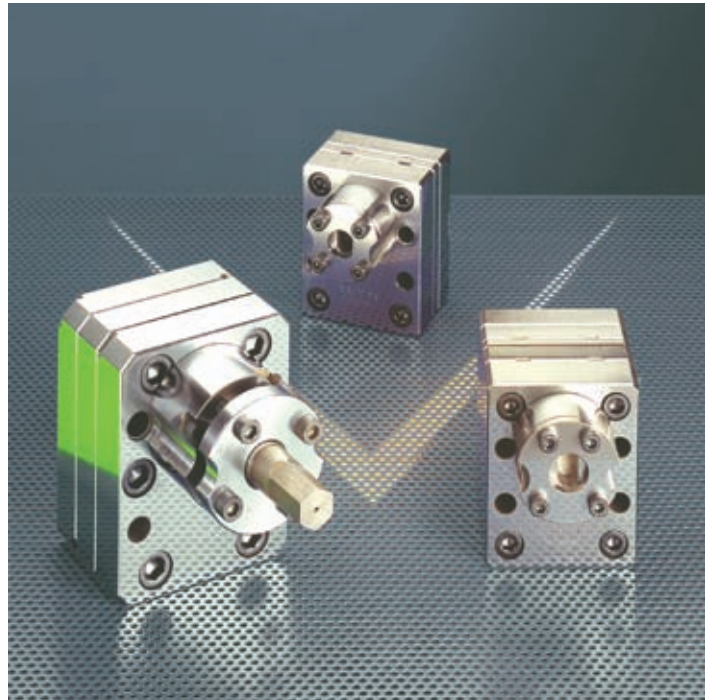

Calculation of the pump size

$$F = \frac{T \cdot v}{10.000 \cdot \rho}$$

- F** = feed volume (cc/rev) per outlet
- T** = spinning denier (dtex)
- v** = take-off velocity in (m/min)
- ρ** = melt density (g/cc)

Result **F** must be divided by the recommended number of revolutions (see data sheets), which will then yield the feed volume (cc/rev) for the gear pump.

Two gear design

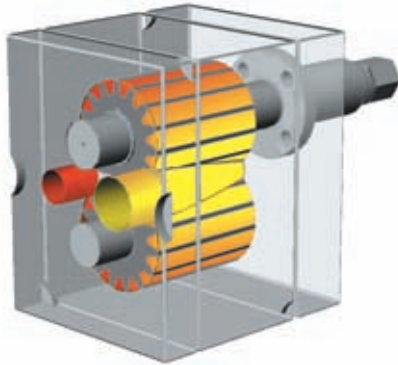

One inlet one outlet
output capacity from 0.3 cc/rev.
to 160 cc/rev.

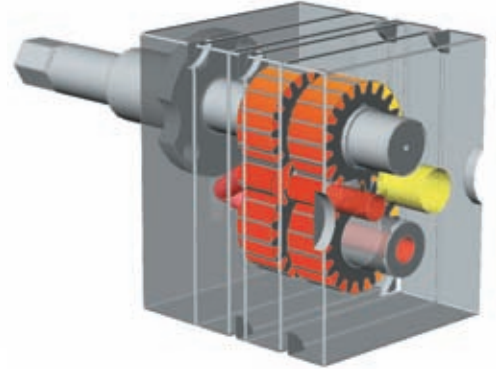

One inlet two outlets
output capacity from 0.3 cc/rev.
to 50 cc/rev.

Three gear design

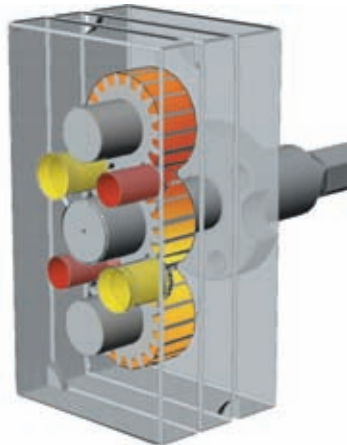

Two inlets two outlets
output capacity from 0.3 cc/rev.
to 30 cc/rev.

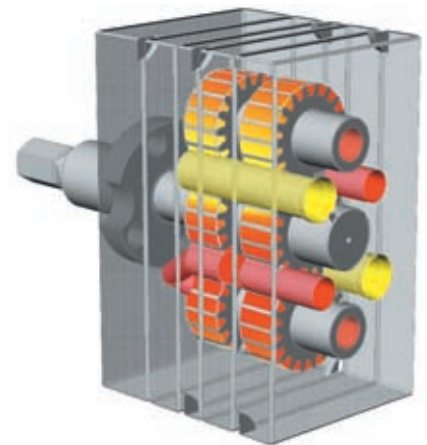

Two inlets four outlets
output capacity from 0.3 cc/rev.
to 15 cc/rev.

Technical details

Depending on the operating conditions and the size of the pump, Oerlikon Barmag can offer rectangular spinning pumps with three (3) different shaft sealing systems. The coupling sealing and stuffing box are the state of the art sealing systems. The selection depends basically on the installation of the pump.

As an alternative, compared to the well known sealing systems, pumps can be equipped with the new development “polymer seal”. This patented sealing system consists of a sealing bushing with thread. When the drive shaft is rotating a resistance is build up, which forces against the melt pressure inside of the pump. This selfsealing system stands for a wearless and maintenance less operation of the spinning pump.

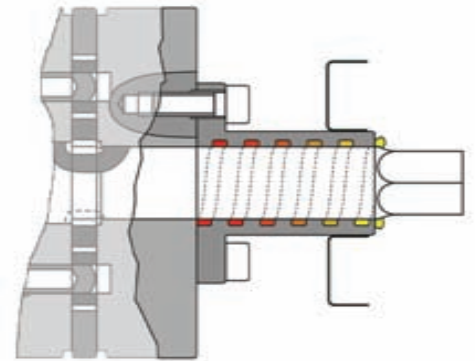

Sealing Systems

Melt spinning pumps are one of the key components in modern spinning plants for the manufacture of synthetic fibers. To ensure, also after several years of production, a uniform yarn quality, the durability is the main factor of successful yarn production.

Oerlikon Barmag spinning pumps are made out of a highly wear resistant high speed tool steel with a maximum cleaning temperature of 550°C (1022°F). For critical applications Oerlikon Barmag offers pump parts made of the special steel HPS-40, which have a better wear resistant behavior because of the high hardness of this steel.

Hardness of Pump Steels

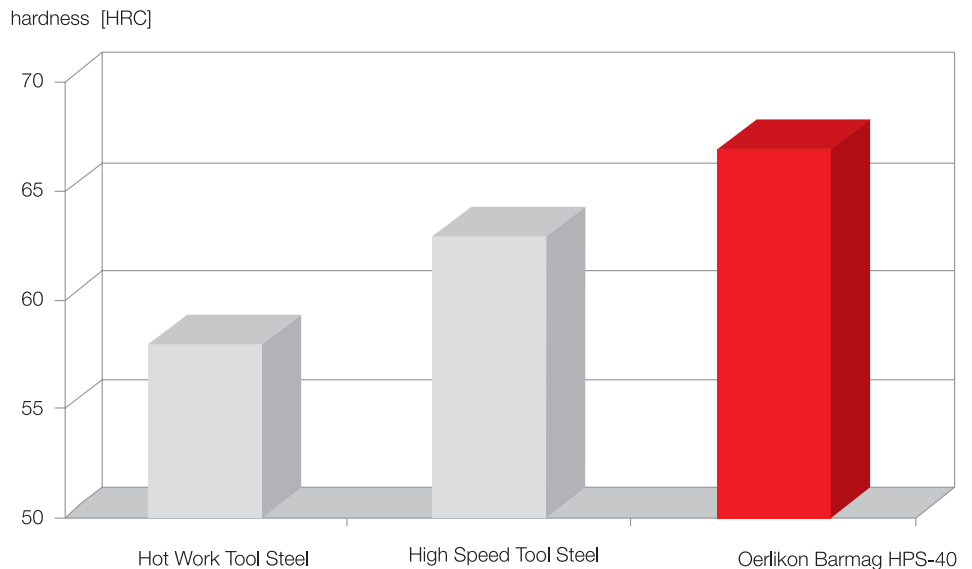

Highly wear resistant steel

Applications

Rectangular melt spinning pumps are mainly used for the following applications:

- Textile yarn
- Carpet yarn
- Melt blown
- Staple fibers
- Technical yarn
- Metering of additives

All common spin polymers can be processed with these pumps.

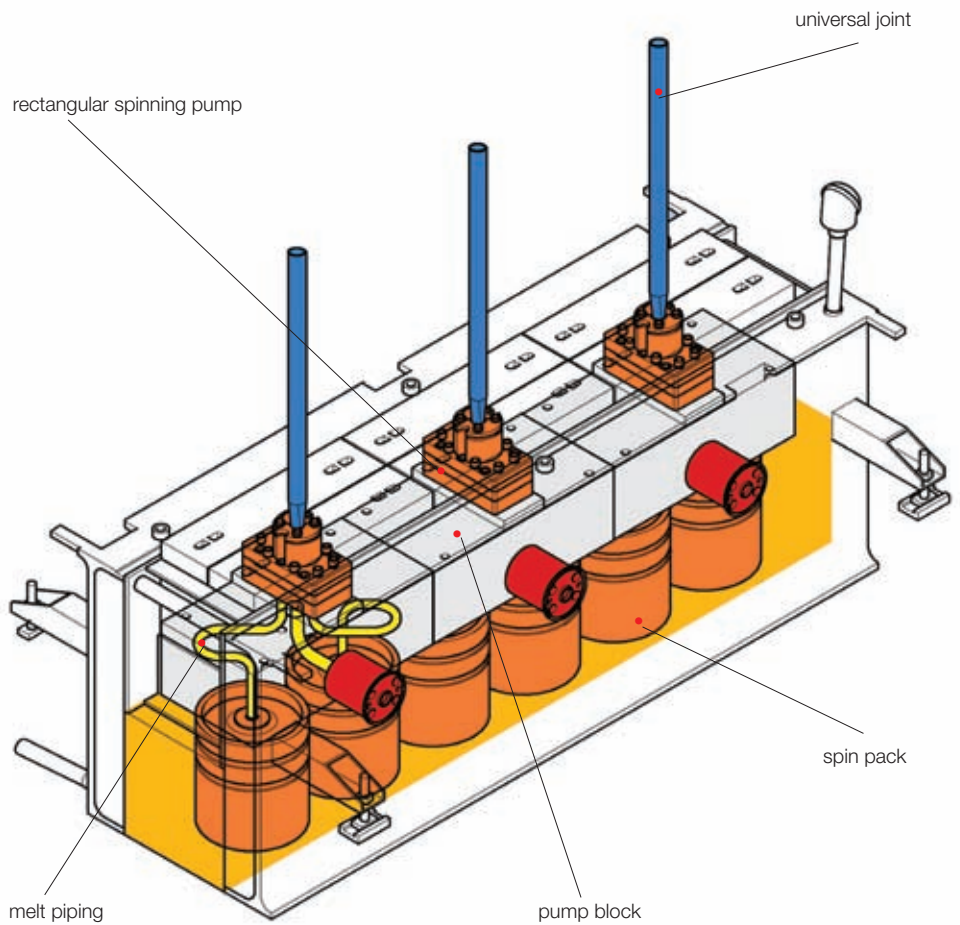

Spin beam SP5x

Oerlikon Barmag

Zweigniederlassung der
Oerlikon Textile GmbH & Co. KG
Leverkuser Straße 65
P.O. Box 11 02 40
D-42862 Remscheid
GERMANY
Phone +49 21 91 67-0
Fax +49 21 91 67-12 04
Internet: www.barmag.com
e-mail: info@barmag.de

Saurer Inc.

8801 South Boulevard
P.O. Box 70 46
Charlotte N.C. 28241
U.S.A.
Phone +1 704 588 00 72
Fax +1 704 588 20 47
info@saurerinc.com

Saurer Far East Ltd.

Units 3806B-3807
38/F, Wu Chung House
213, Queen's Road East
Wanchai, HONG KONG
P.R.CHINA
Phone +852 28 27 43 14
Fax +852 28 27 52 50
barmaghk@netvigator.com

Saurer India Pvt. Ltd.

306-309, Dalamal Tower
Nariman Point
Mumbai 400 021
INDIA
Phone +91 22 2850 813
Fax +91 22 2044 322
management@saurerindia.com

The information supplied in this
brochure is for guidance only.
We reserve the right to modify it
at any time.